

FRONT ELEVATION
A/25264/86/98

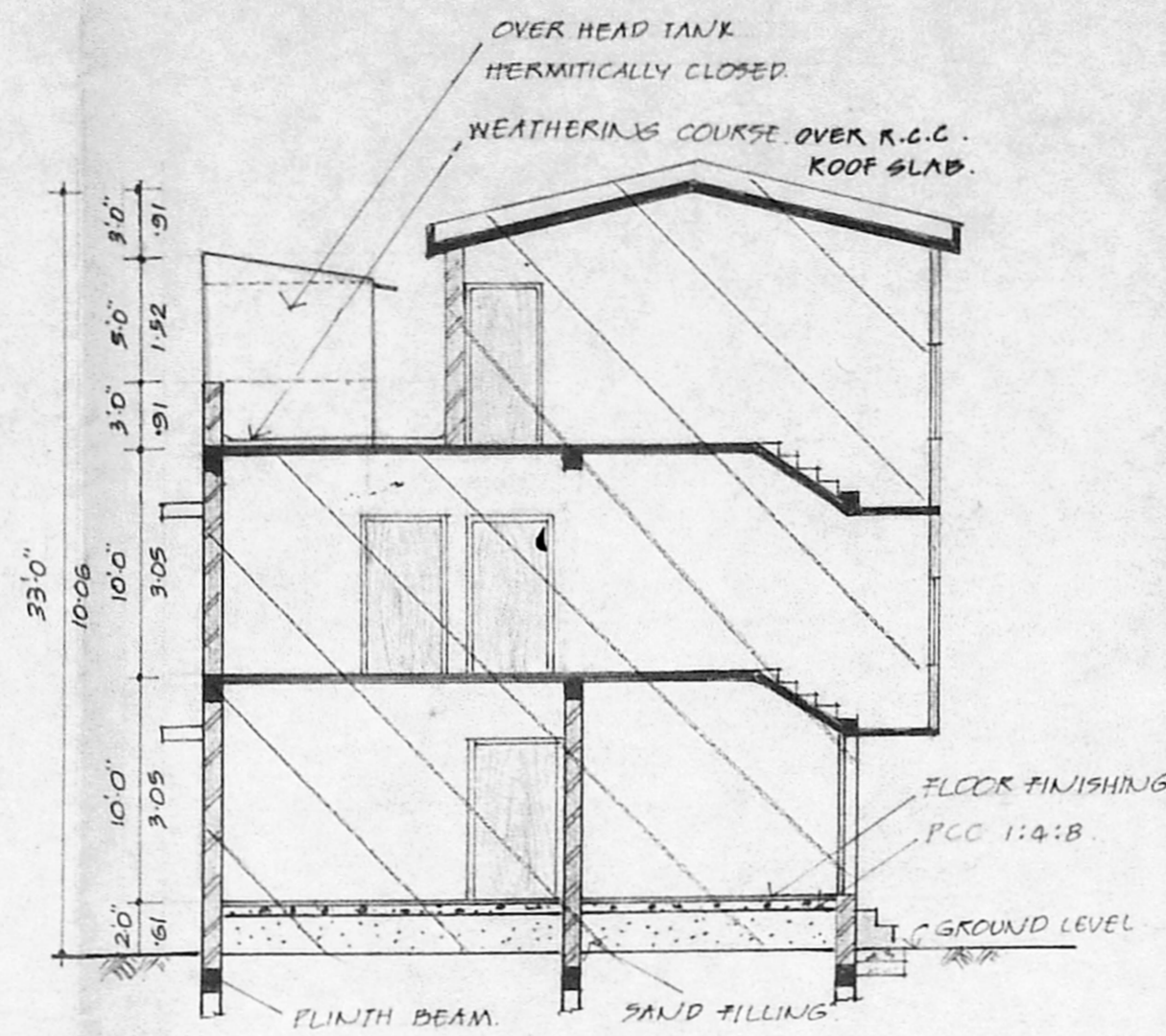

SECTION ON 'A.B'

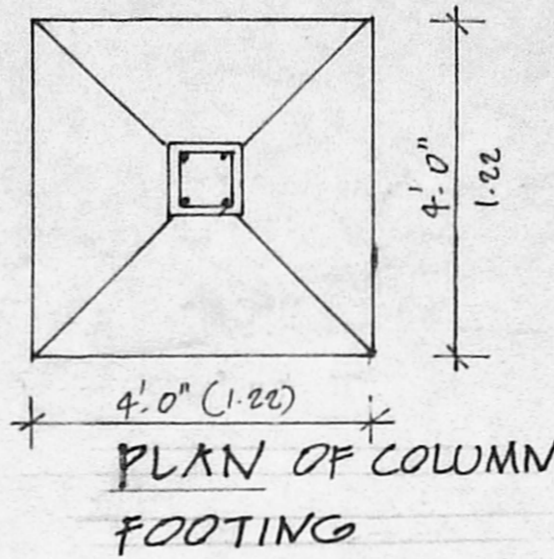

PLAN OF COLUMN FOOTING

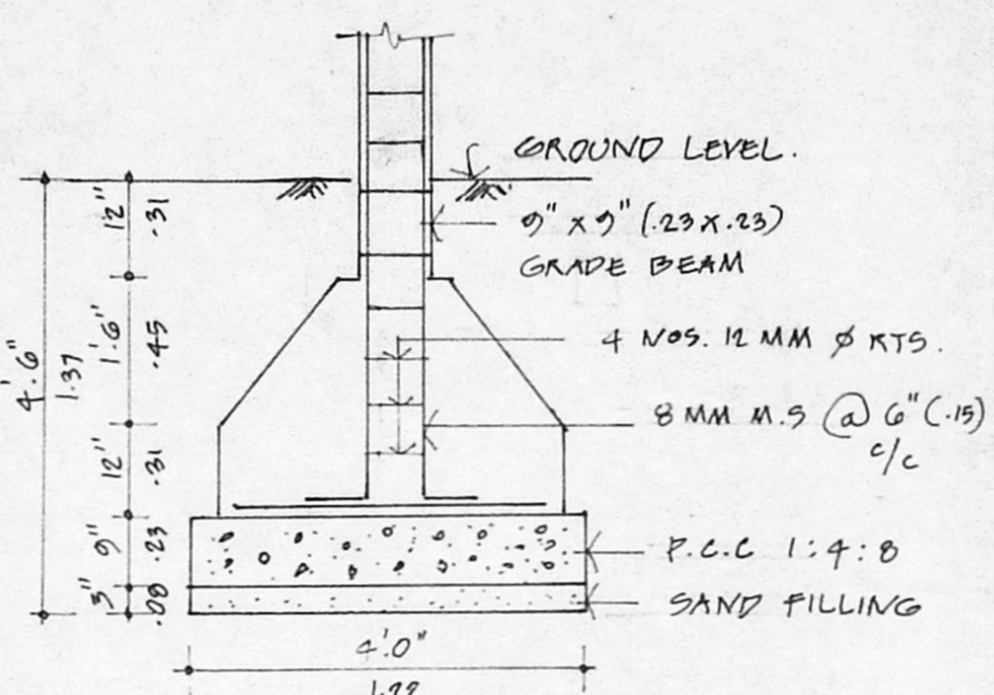

SECTION OF COLUMN FOOTING

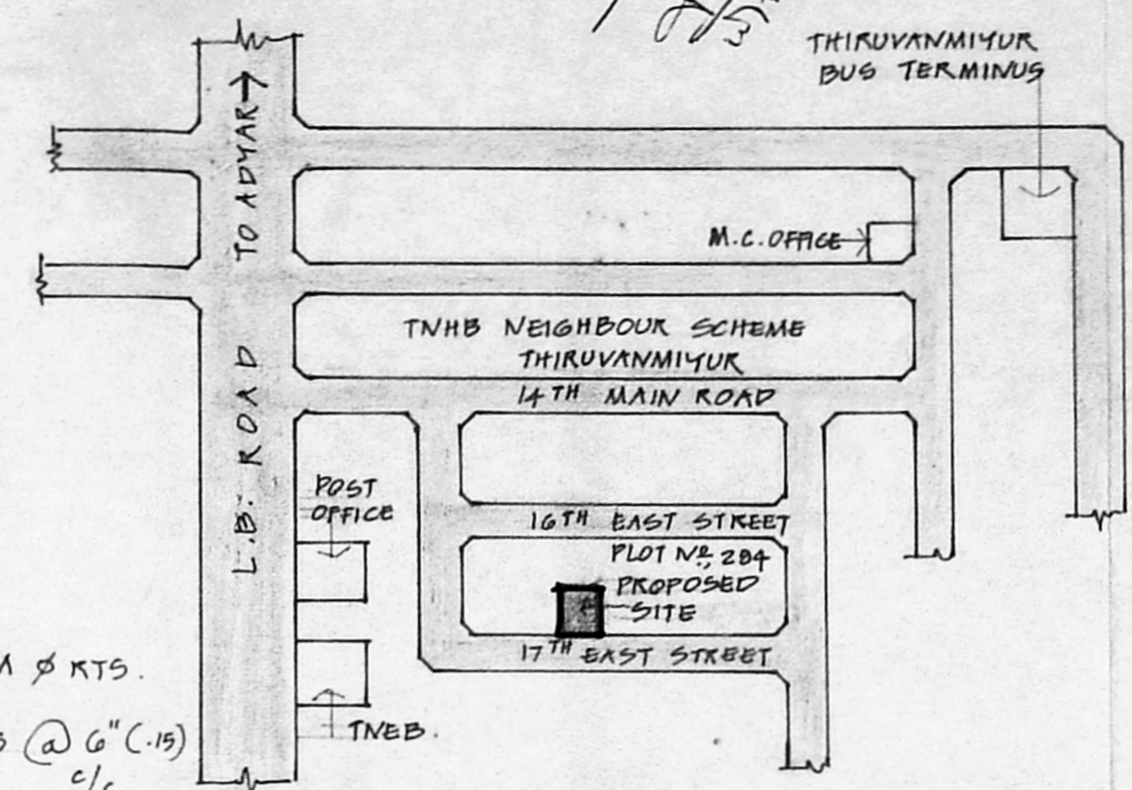

KEY PLAN
NOT TO SCALE

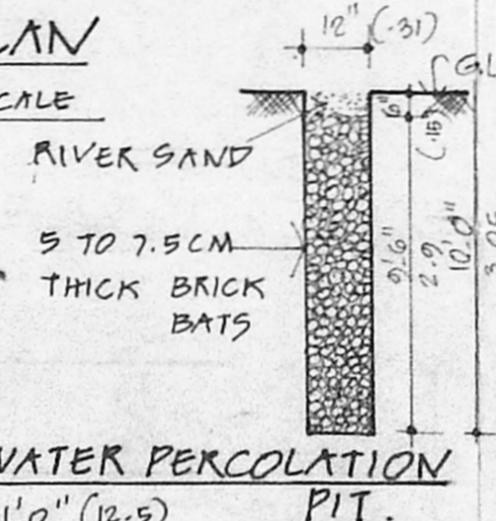

RAIN WATER PERCOLATION PIT.

Planning Permit No. **A/25264/86/98**
APPROVED
SUBJECT TO THE CONDITIONS IN THIS OFFICE LETTER.
Date: **5-7-98**
FOR MEMBER SECRETARY
CHENNAI METROPOLITAN
DEVELOPMENT AUTHORITY
CHENNAI - 600 003.

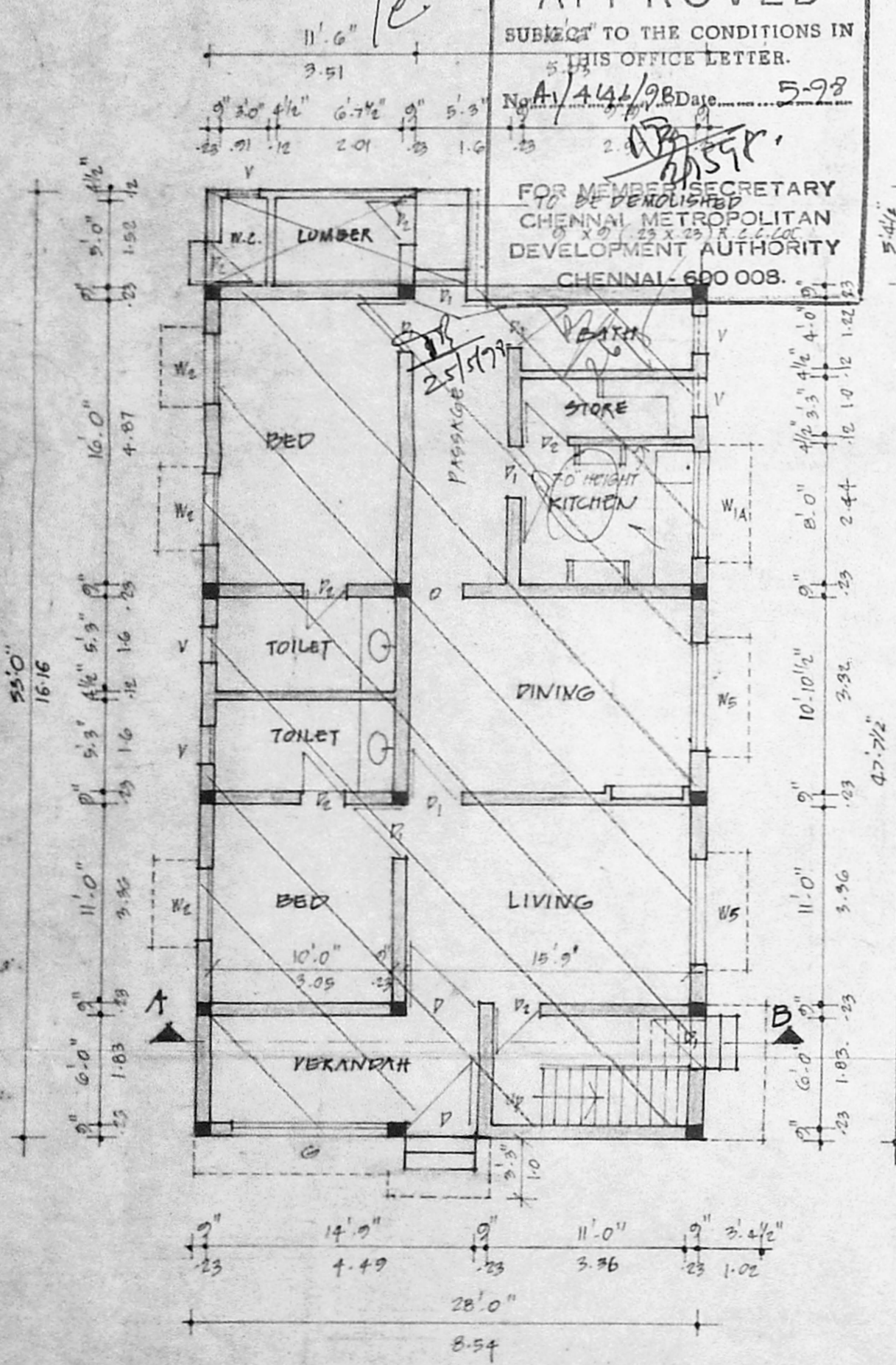

GROUND FLOOR PLAN

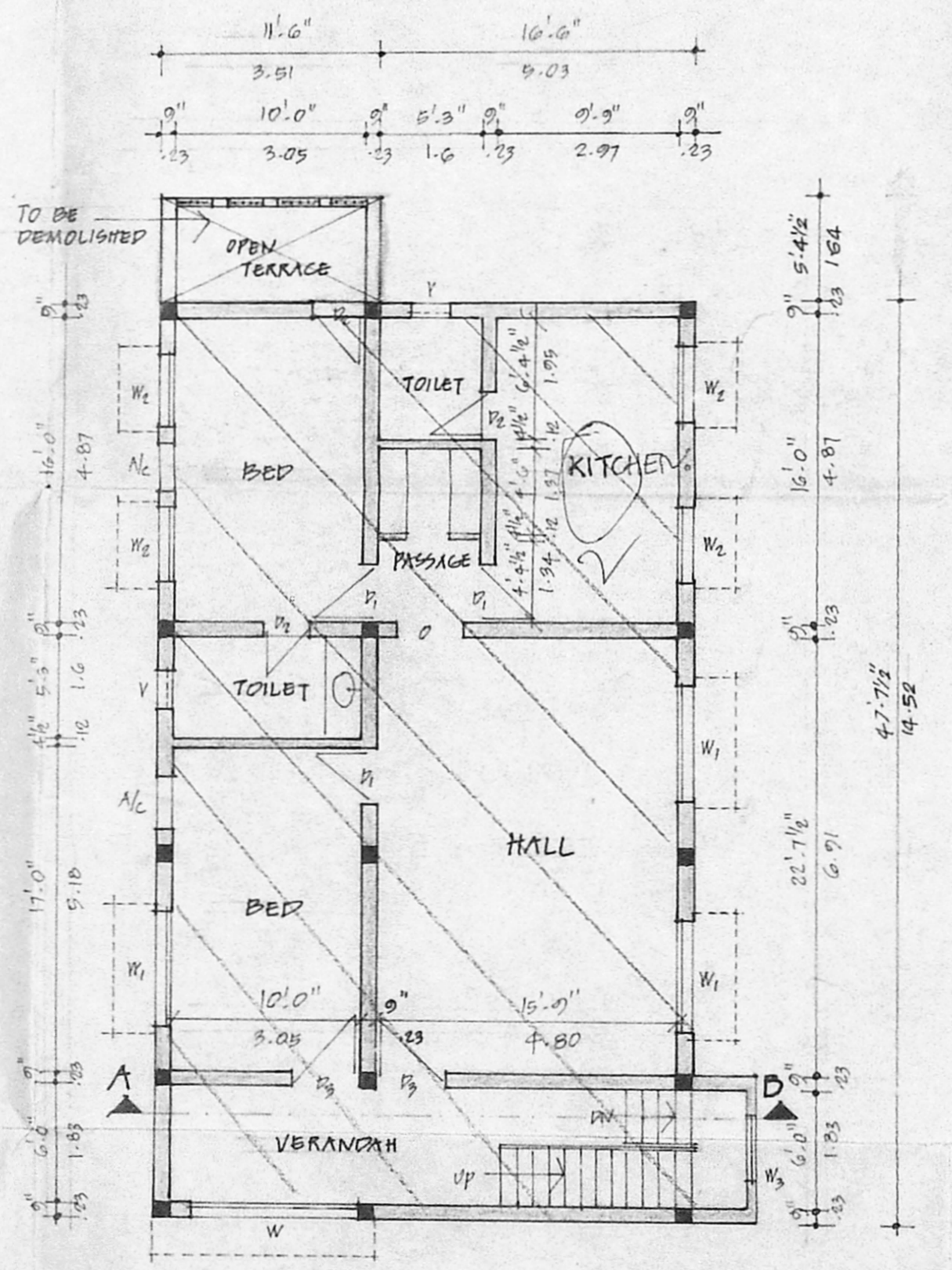

FIRST FLOOR PLAN

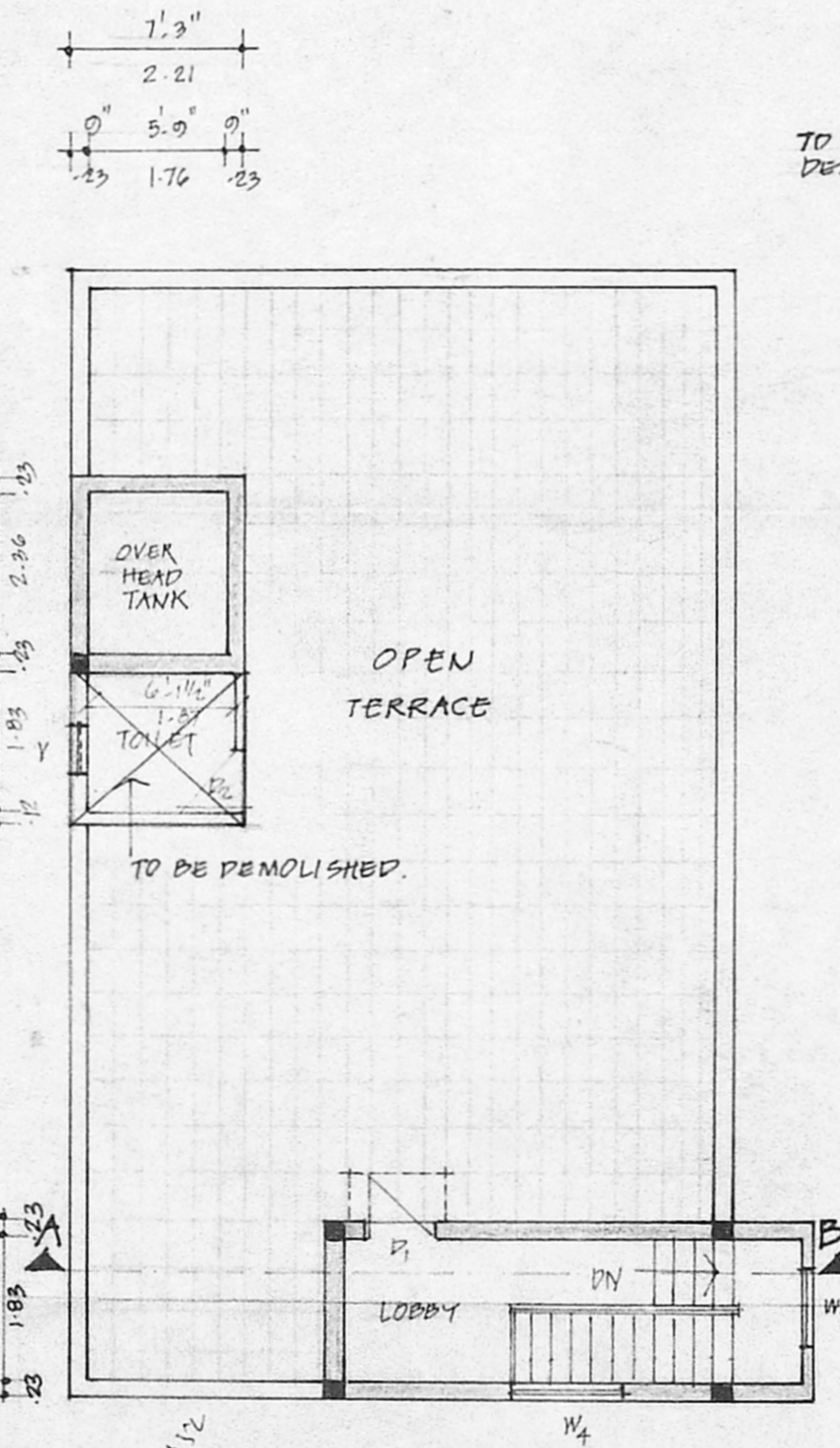

TERRACE FLOOR PLAN

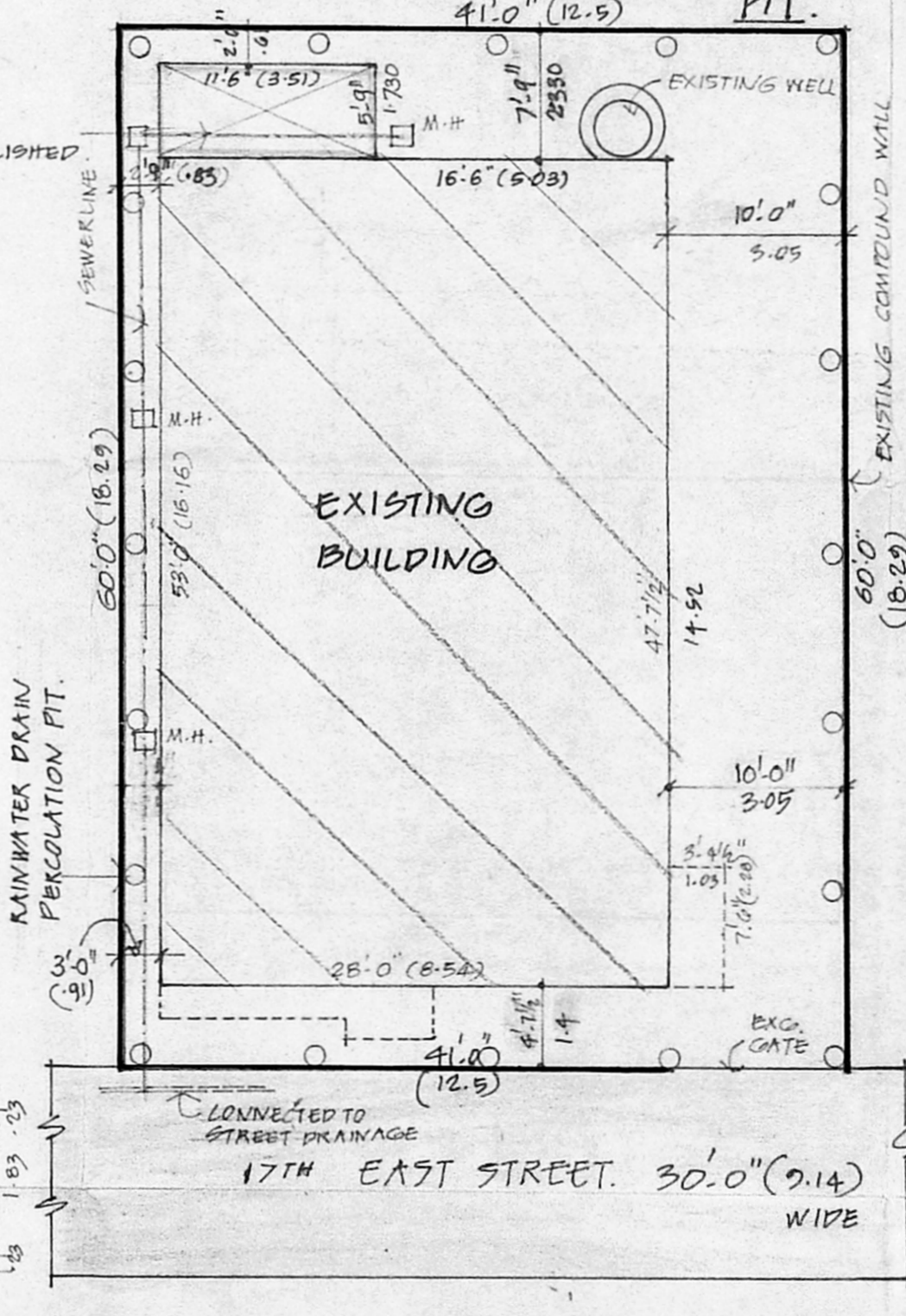

SITE PLAN
SCALE: 0'-1" TO 10'-0" (OR) 1:120

SPECIFICATION:
G.C. 1:4:8 FOR FOUNDATION & FLOORING
PLASTER WORK IN CM 1:3 FOR ALL MASONRY WORKS
PLASTERING IN CM 1:4, 12 MM THICK.
WOOD WORK WITH TEAK WOOD.
ROOFING WITH R.C.C. 4" THICK.
FLOOR FINISH WITH MOSAIC.
WEATHERING COURSE OVER R.C.C. ROOF SLAB LAID TO SLOPE.

AREA DETAILS:
PLOT AREA : 2460 SQ. FT. (228.54 m²)
AREA OF GROUND FLOOR : 1323.55 SQ. FT. (123.89 m²)
AREA OF FIRST FLOOR : 1358.85 SQ. FT. (126.24 m²)
TOTAL BUILT UP AREA : 2682.35 SQ. FT. (250.13 m²)
PLOT COVERAGE : 55.23%
F.S.I. : 1.09
HEAD ROOM : 155 SQ. FT. (14.4 m²)

SCHEDULE OF JOINERY:

D	T.W. DOOR	4'-0" x 7'-0" (1.22 x 2.13)
D ₁	DO	3'-0" x 7'-0" (0.91 x 2.13)
D ₂	C.W. DOOR	2'-6" x 7'-0" (0.76 x 2.13)
D ₃	T.W. DOOR	3'-6" x 7'-0" (1.06 x 2.13)
W ₁	T.W. GLAZED WINDOW	8'-6" x 4'-0" (2.59 x 1.22)
W ₂	DO	6'-0" x 4'-0" (1.83 x 1.22)
W ₃	DO	4'-0" x 4'-0" (1.22 x 1.22)
W ₄	DO	3'-6" x 4'-0" (1.06 x 1.22)
W ₅	DO	4'-6" x 6'-0" (1.37 x 1.83)
V	T.W. GLAZED VENTILATOR	2'-0" x 2'-0" (0.61 x 0.61)
G	GRILL	8'-6" x 4'-0" (2.59 x 1.22)
W ₅	T.W. GLAZED WINDOW	6'-0" x 6'-0" (1.83 x 1.83)
W ₆	DO	6'-0" x 6'-0" (1.83 x 1.83)

PLAN SHOWING THE REGULARIZATION OF THE EXISTING RESIDENTIAL BUILDING AT DOOR NO. 16, PLOT NO. 284, T.N.H.B. LAY-OUT, THIRUVANMIYUR, CHENNAI-41. NEIGHBOURHOOD SCHEME. SURVEY NO. 73/3B PART.

COLOUR INDEX:
EXISTING BUILDING [Hatched Box]
EXISTING TO BE DEMOLISHED [Dotted Box]
BOUNDARY [Solid Line]
ROAD [Double Line]
SEWER LINE [Dashed Line]

SCALE: 0'-1" TO 8'-0" (1:100)
x 0'-1" TO 10'-0" (1:120)
ALL METRIC DIMENSIONS ARE IN METRES.

P. Sarala
OWNER'S SIGNATURE

P.J. PRABAHARAN, B.E.,
Licenced Surveyor Class I No. 45,
Corporation of Madras & Ambattur Municipality,
139/1, Kailash Colony, Anna Nagar West extn.,
MADRAS - 600 101. Phone: 6216221

LICENSED SURVEYOR